

DUSUP GUIDELINES FOR ROAD & RAIL INFRASTRUCTURE CROSSING

Document Number:	DP-OPSON-0152	Document Owner:	Neil Bennie
Revision Code:	02	Content Owner:	Ali Alsayegh
Issue Date:	28/01/2025	Information Security Classification:	Public

Approval

This Guideline for Road and Rail Infrastructure Crossing was published on 29/01/2025.

TABLE OF CONTENTS

1 INTRODUCTION 4

2 PURPOSE 4

3 REFERENCES 4

4 ABBREVIATIONS AND DEFINITIONS 4

 4.1 Abbreviations: 4

 4.2 Definitions: 5

5 ROAD AND RAIL INFRASTRUCTURE CROSSING EXISTING PIPELINES..... 8

 5.1 NOC Type & Submission Requirements: 8

 5.1.1 Information NOC: 8

 5.1.2 Submission Requirements:..... 8

 5.1.3 Concept Design NOC/Route NOC/Preliminary Design NOC 9

 5.1.4 Final Design NOC 9

 5.1.5 Submission Requirements:..... 9

 5.2 General Design Considerations 9

 5.3 Trial Pit 10

 5.4 Construction NOC Submission & Construction Requirements:..... 10

 5.4.1 Submission Requirements:..... 10

 5.4.2 Construction Requirements: 11

6 DUSUP NOC CLOSEOUT 20

7 DUSUP GUIDELINES 20

List of Attachments

Attachment 1: Pipeline Protection Slab..... 21

Attachment 2: Pipeline Protection at Road Curves 22

Attachment 3: Crash Barriers at Block Valve Stations 23

Attachment 4: Pipeline Warning Signs..... 24

Attachment 5: Corridor Fence..... 25

Attachment 6: Corridor Gate..... 26

Attachment 7: Fence Sign 27

1 INTRODUCTION

Dubai Supply Authority (DUSUP) provides energy supply (Natural Gas) to Emirate of Dubai to meet the needs of electricity generation and water desalination through its pipeline network, Through the production of natural gas (which is processed into gas and condensate products), the purchase of pipeline gas and LNG (and its regasification), gas storage and the operation of the pipeline network, DUSUP plays a key role in the growth and development of Dubai.

DUSUP has assigned Dubai Petroleum Establishment (DPE) the responsibility for operating DUSUP assets and authorised DPE to manage all emergency events occurring on its own operated facilities, pipelines and assets within pipeline corridors in liaison with other governmental entities.

DPE-DUSUP designs operates and maintains DUSUP's onshore pipelines and related facilities to International Standards in order to ensure an uninterrupted flow of gas and other hydrocarbons across Dubai.

There are approximately 700 kilometres of onshore hydrocarbon pipelines operating in Dubai. The gas pipelines operate at high-pressures up to 960-psig and transport highly explosive and flammable natural gas. A number of jet fuel and fuel oil pipelines share the corridors with the gas and condensate pipelines.

2 PURPOSE

The purpose of this guideline is to assist the DUSUP/DPE NOC staff for NOC review, and NOC applicants and field staff for monitoring safe execution of road and railway infrastructure works affecting DUSUP/DPE pipelines and pipelines assets.

3 REFERENCES

DUSUP NOC Standard Conditions - DP-OPSON-0056

DUSUP Guidelines for Trial Pit: DP-OPSON-0148

DPE Hot Work Procedure - DPE-HSE-00044

AREMA - Chapter 5 - Pipelines

Gas Transmission and Distribution Piping Systems – ASME B31.8

Pipeline Transportation Systems for Liquids and Slurries - ASME B31.4

Steel Pipelines Crossing Railroads and Highways – API RP 1102

4 ABBREVIATIONS AND DEFINITIONS

4.1 Abbreviations:

Abbreviation	Description
ALARP	As Low As Reasonably Practicable
AREMA	American Railway Engineering and Maintenance - of - Way Association
CP	Cathodic Protection
DEWA	Dubai Electricity and Water Authority
DM	Dubai Municipality

Abbreviation	Description
DEL	Dolphin Energy Limited
DPE	Dubai Petroleum Establishment
DX	Desert Crossing
EMDAD	EMARAT, Air BP and Shell Joint Venture
EMARAT	Emirates General Petroleum Corporation
ENOC	Emirates National Oil Company
e-NOC	Electronic NOC
GCS	Gas Control Station
HSE	Health, Safety and Environment
JAFZA	Jebel Ali Free Zone Authority
MS	Method Statement
MSE	Mechanically Stabilised Earth
MSRA	Method Statement and Risk Assessment
NOC	No Objection Certificate
PPE	Personal Protective Equipment
PPV	Peak Particle Velocity
PTW	Permit to Work
RA	Risk Analysis
RCC	Reinforced Cement Concrete
ROW	Road Right of Way
RTA	Roads and Transport Authority
RX	Road Crossing
TRA	Task Based Risk Analysis

4.2 Definitions:

Term	Definition
Accident	The unexpected and undesirable occurrence directly associated with DUSUP operations and DUSUP asset/facility, which results or may result in human casualties or damage to property.
Angle of Repose	Angle of repose of a granular material is the steepest angle of descent or dip relative to the horizontal plane to which a material can be piled without slumping.
Applicant/Customer	Any party applying for a No Objection Certificate.
At Grade Crossing	For the purpose of pipeline protection, the carriageway crossing at same level of adjacent ground or not more than 5'-0" (1.5meter)

Term	Definition
	above adjacent ground/pipeline corridor to be considered as "At Grade Crossing".
Battering	Sloping the exposed face of an excavation wall back either at a uniform angle, or stepping it back uniformly.
Benching	Method of preventing collapse of excavation walls by excavating the sides of an excavation to form one or a series of horizontal levels or steps, usually with vertical or near-vertical surfaces between levels.
Berm	A soil bund built over the pipeline as a protection cover.
Bridge	A bridge is a structure built to span a physical obstacle without blocking the way underneath in order to provide passage over the obstacle.
Construction	The erection of any new buildings or structures, or the variations to the Infrastructure facilities or existing asset.
Consultant	A natural or legal person who is offering advice/consultation on engineering, technical, or any other matter related to design and construction.
Contractor	An organization designated by the Owner or the Operator for the purpose of carrying out the works related to Construction, or execution of any work that requires obtaining of No Objection Certificates from the DUSUP.
Control Measure	Provisions to reduce identified risks.
Cathodic Protection	Cathodic Protection (CP) is a technique used to control the corrosion of a metal surface by making it the cathode of an electrochemical cell. A simple method of protection connects the metal to be protected to a more easily corroded "sacrificial metal" to act as the anode.
DPE	Dubai Petroleum Establishment responsible for the Operation of DUSUP Asset.
DUSUP Corridor	DUSUP Corridor is the land allocated by Dubai Municipality or other statutory government authority to DUSUP for the construction, operation and maintenance of gas and fuel pipelines in the emirates of Dubai.
Elevated Road	A road raised 1.5 meter or more above grade.
e-NOC	The electronic NOC application that can be submitted via the online system : https://noc.rta.ae/RTAeNOC/Webpages/common/login/login.aspx
Embankment	A mound of earth built to carry a road or railway over an area of low ground.
Excavation	Excavation is a man-made cut, cavity, trench or depression formed by earth removal.
Hazard	A Hazard is any source of potential damage, harm or adverse effects on people, property environment or organization.

Term	Definition
Incident	An occurrence which affects or could affect the safety of people or the DUSUP asset.
Lifting Operation	An operation concerned with the lifting and lowering of a load which has the potential to have an adverse effect upon the existing DUSUP asset. A load is the item or items being lifted. A lifting operation may be performed manually or using lifting equipment such as crane.
No Objection Certificate (NOC)	A document approved by the DUSUP through e-NOC, for the technical design of proposed development or authorizing a contractor to carry out a Construction/Restricted Activity within the NOC Zones.
PERMIT TO WORK (PTW)	A written or digital approval granted by DPE that authorises a person or persons to carry out specific work within a specified time frame within the proximity of DUSUP asset/plot boundary limit.
Pipeline Representative, Pipeline Operator or Patrol staff	The staff designated by DUSUP the duties of witnessing NOC works for compliance with NOC conditions and monitoring the safety of the pipelines.
Risk	A situation involving exposure to danger
Risk Assessment	A report prepared by the Applicant/Customer seeking DUSUP NOCs, identifying potential risks and mitigation measures involved in carrying out any Construction or Restricted Activity within the DUSUP NOC Zones.
Road Interchange	Road interchange is a junction of two or more major roads by a system of separate levels that permit traffic to pass from one to another without the crossing of traffic stream.
Safety	The absence of any risk of harm or damage to the people, DUSUP asset/Infrastructure that is deemed unacceptable as per the DUSUP/DPE Safety Regulation or Standard Operating Procedure.
Shoring	Shoring is the form of prop or support, usually temporary that is used for supporting a structure or sides of excavation when in danger of collapse or cave-in.
Trench	A Trench is a narrow excavation. The depth is greater than the width, but not wider than 15 feet.
Viaduct	Viaduct is a specific type of bridge that consists of a series of arches, piers or columns supporting a long elevated road or railway.
Witnessing Zone	Work within 10 meters of hydrocarbon pipeline which can only be carried in the presence (witnessing) of DUSUP Pipeline Representative.
Zone of influence	The area over which applied external loads (e.g: vehicles, plant, excavated material) are likely to affect the volume of soil around the excavation, a structure below ground or adjacent to the external load.

5 ROAD AND RAIL INFRASTRUCTURE CROSSING EXISTING PIPELINES

New and upgraded road and rail infrastructure may require to cross the existing DUSUP/DPE pipelines or DUSUP corridor in various locations of Dubai. The design and construction of such crossings requires review and approval through the NOC process.

DUSUP receives and process NOCs through the Dubai Government e-NOC (electronic NOC) system administered by RTA. The link for e-NOC application is:

<https://noc.rta.ae/RTAeNOC/Webpages/common/login/login.aspx>

DUSUP NOC is issued for hydrocarbon pipelines that are owned and operated by DUSUP/ DPE, ENOC, EMDAD and Dolphin Energy.

Subsequent sections stipulates the minimum requirements to be followed in order to obtain an NOC.

5.1 NOC Type & Submission Requirements:

DUSUP NOC's are typically issued in the following sequence:

- Information NOC
- Concept Design NOC/Route NOC/Preliminary Design NOC
- Final Design NOC
- Trial Pit NOC
- Construction NOC
- Final Clearance / NOC Close-out

5.1.1 Information NOC:

Existing, planned pipeline and related facility information along with the corresponding DUSUP Guidelines and Standard DUSUP NOC Conditions are shared with the consultant or contractor for the design of their planned developments or construction through e-NOC System.

5.1.2 Submission Requirements:

- a) AutoCAD drawing on DLTM coordinates datum showing the proposed Project Limit Plan for issuing Pipeline Information.
- b) Pdf file of drawing(s) showing the proposed Project Limit Plan for issuing Pipeline Information.
- c) For issuing Pipeline information, it is mandatory for the applicant to submit a confidentiality undertaking letter as per the DUSUP approved letter template. The Confidentiality Undertaking Letter template can be downloaded from DUSUP website using link <https://www.dusup.ae/noc>
- d) Undertaking letter must be submitted with company stamp and signed by the authorized company representative.

Note: Information NOC will be issued with DUSUP Standard NOC Conditions, AutoCAD file of existing pipeline information, corridor limits, corridor fence and gate locations, desert crossings and other facilities such as block valve station and pigging facilities and applicable guidelines.

5.1.3 Concept Design NOC/Route NOC/Preliminary Design NOC

Concept Design NOC/Route NOC/Preliminary Design NOC are initial design proposal seeking input and approval in order to proceed with the Final Design.

5.1.4 Final Design NOC

Final Design NOC is submitted after incorporating Preliminary Design NOC conditions. A check list for Preliminary Design NOC conditions compliance must be included in the submission of Final Design NOC.

To manage the change to DUSUPs corridor from critical construction designs such as a railway crossing may require third party review by the DUSUP/DPE approved specialist consultant. Such design review typically exceeds standard review duration. The applicant shall make suitable allowance for the extended review period by specialist consultant in their schedule.

5.1.5 Submission Requirements:

- a) Key Plan showing project location.
- b) General Layout Plan incorporating existing and proposed work, DUSUP corridor, pipelines/ facilities as provided in Information NOC.
- c) AutoCAD file of General Layout Plan drawing prepared on DLTM coordinates datum.
- d) Typical Cross Section drawings showing proposed work incorporating DUSUP Standard NOC Conditions, pipeline information provided through the Information NOC, minimum vertical separation from the existing pipeline to the proposed crossing , and any element of work having direct or indirect effect on or in the proximity of DUSUP pipelines.
- e) Applicable design considerations mentioned in this document shall be considered for the design and drawing.

5.2 General Design Considerations

- a) Safety in design should be paramount, with due consideration of safe methods for the construction of the works and the ability to apply adequate controls for these activities. The design documents must take into account the requirements outlined within this document, along with any other controls that may be required by DUSUP.
- b) Where practicable, roads and railways shall cross the pipeline corridor at approximately right angles thereto but at not less than 45 degrees.
- c) The consultant must verify site conditions that could affect the safety and practicability of construction or operation in the presence of existing or planned DUSUP facilities (particularly above ground pipelines or block valve stations in the proximity of construction).
- d) Existing DUSUP pipeline assets or facilities affected by the proposed road works such as CP Test posts, vent pipes and warning signs etc., shall be relocated to the approval of DUSUP and all costs shall be borne by the Contractor.
- e) Design of road / railway bridge crossings must consider that the empty space available in the existing DUSUP corridor is reserved for the construction of future pipeline(s); therefore where practicable, foundations within the corridor shall be avoided or the design must consider the use of bare minimum corridor space subject to review and approval of DUSUP. Contractor shall reduce the number of foundations within the corridor to as far as possible, and shall present other alternative design in their design to assist in reducing the requirements for foundations.

- f) Minimum horizontal distance from the edge of the existing pipeline to the edge of the road/railway bridge foundation or any structure must be 5.0 meters.
- g) Drilled piles shall be located at minimum 15 meters separation distance from the existing pipeline. However, separation distance from the drilled pile may be reduced up to minimum 5.0 meter provided detail risk analysis of proposal is carried out to demonstrate that the risk have been mitigated to As Low As Reasonably Possible (ALARP).
- h) Any installation such as gantry signs, street lights, wing walls, culvert, manholes in the vicinity of pipeline must consider safe access to the gas/fuel pipeline in case of emergency access, i.e., that adequate separation be maintained so that when excavating the gas/fuel pipeline or other related asset, that there is no risk of the installed structure toppling / collapsing or otherwise effecting the gas/fuel pipeline or the personnel working on that gas/fuel pipeline.
- i) The design of road/road interchanges /railway crossing of pipeline corridor must consider safe patrolling and routine operations access in order that DUSUP must have unrestricted right of way and access for the operation & maintenance of the existing pipelines (including emergencies and daily two way patrolling).
- j) The road and railway design must include a study carried out on the impact of vibration on the existing pipelines and necessary mitigation measures for DUSUP review and approval.
- k) If the soil fill/height of embankment above DUSUP pipeline exceeds 4.9m, the road consultant/contractor shall engage DUSUP/DPE approved specialist consultant to carryout out an overburden study to check the effect of weight of soil overburden, live surface loading including use of construction equipment's above pipeline(s) and design a location specific pipeline protection to ensure that the pipeline integrity remain intact.
- l) For new road crossings of the DUSUP corridor that split the DUSUP corridor into two corridors (i.e. entrance road crossing the DUSUP corridor for a new development), consultant shall include a form of culvert to allow DUSUP to utilize the culvert for future dewatering between the DUSUP fenced corridors. Culvert size shall be minimum 16" to allow dewatering hose to pass through.

5.3 Trial Pit

For Trial Pit NOC Requirements refer to:

DUSUP Guidelines for Trial Pit: DP-OPSON-0148

5.4 Construction NOC Submission & Construction Requirements:

Any activities occurring near gas pipeline infrastructure require due consideration of the risks and controls to ensure they can be conducted safely. At closer proximity the risk and extent of controls will increase accordingly

Activities that are likely to result in high vibration levels have increased ranges of influence where they may impact the safety of the gas/fuel pipelines.

Following are the minimum requirements for Construction NOC submission and Construction of Road and Railway works crossing pipelines/corridor.

5.4.1 Submission Requirements:

Construction NOC submission must include but not limited to following:

- a) Key Plan Showing Project Location.

- b) General Layout Plan on DLTM Coordinates datum, incorporating existing and proposed, temporary and permanent work, DUSUP corridor limits, fence & gates, access arrangement and pipelines / facilities as provided in Information NOC.
- c) Bridge /Interchange structure General Arrangement drawing, if applicable.
- d) Detail Cross Section drawings showing:
 - The elevation of existing ground, pipeline berm, proposed finished ground, DUSUP corridor limit, all temporary and permanent construction within DUSUP NOC Zone.
 - Vertical separation from the existing pipeline to the proposed crossing, elevations and location coordinates as per the trial pit verification.
 - Hazard Analysis for railway crossing covering all construction activities, vibration, derailment mitigation, and applicable stray current mitigation.
 - Client confirmation of stray current monitoring and reporting during the commissioning and operation.
- e) DUSUP patrolling access layout approved by RTA's concerned departments.
- f) Include applicable notes from the DUSUP Standard NOC Conditions in the drawing.
- g) DUSUP field verified copies of trial pit record.
- h) Completed check list for Design NOC condition compliance.
- i) Job specific and location specific method statement and TRA (Task Risk Assessment) with particular attention to safety of DUSUP pipeline and DUSUP/DPE assets.
- j) Vehicle Movement Plan above the pipelines (if applicable) and within the pipeline corridor. Vehicle movement plan shall include the routes for the vehicles, location and details of the existing and new protection slabs above the pipelines at designated crossings, appropriate barriers, details of flag men and effective ways of communication between the flag men and vehicle drivers to ensure the safe passage of personnel and vehicles in the area.

5.4.2 Construction Requirements:

Construction of road or railway infrastructure at grade or on soil embankment may require major soil backfill and compaction works using heavy equipment's. The construction of road and railway crossing of gas and fuel pipelines must consider following requirements, but not limited to:

5.4.2.1 Excavation and Backfill

- a) Conditions set in DUSUP Guidelines for Trial Pit (DP-OPSON-0148) shall be followed for excavation and backfill.

5.4.2.2 Vibration during the Construction and Operation

Activities likely to result in high vibration levels have increased ranges of influence where they may impact the safety of the gas/fuel pipeline.

- a) The vibration level on the pipeline(s) shall be measured for the worst case scenarios. After measurement, if any mitigation is required then the contractor must carry out approved mitigation measures. The vibration level (peak particle velocity) at the pipeline must be less than 40 mm/s.

- b) Use of vibratory construction equipment's are typically not permitted within 10 meters of pipeline. However compaction with roller compactor on non-vibratory mode may be permitted if the pipeline is protected as per DUSUP approved protection design and minimum 300mm soil cover is available over the protection slabs.
- c) Use of specifically identified road roller in vibration mode for the compaction of road embankment may be permitted provided if the contractor demonstrate that the vibration level on the pipeline from specified road roller remains within the prescribed limit of 40 mm/s and submission is reviewed and approved by DUSUP.
- d) Approved vibration isolation matt / material may be provided under the railway track to reduce the vibration propagations to the existing pipeline.

5.4.2.3 Inspection and Rehabilitation of Pipeline Coating

- a) Where the existing DUSUP pipelines falls under the proposed carriage way/railway, the pipeline(s) covered under the road infrastructure and railway restricted zone must be exposed with a minimum one (1) meter working space all-around for coating inspection and assessment to be carried out by the DUSUP/DPE approved coating specialist. DUSUP shall provide a list of the DUSUP approved coating specialist to contractor who shall coordinate the coating repair with the specialist and bear the cost of repair.
- b) For repairs, the contractor must excavate the pipeline for site handed over to DUSUP for coating repair. All cost of coating repair shall be borne by the road contractor. Refer to Section 5.4.2.1 for excavation and backfill requirements.
- c) Note: DUSUP/DPE Pipeline Operations Superintendent typically performs the assessment of the coating condition and repairs, should they be necessary, during the trial pit excavations and prior to proceeding with the protection construction.
- d) For approved structures above the pipeline that will make the pipeline inaccessible in the future (i.e., under an MSE wall or an RTA road), the pipeline(s) shall be appropriately exposed and coated regardless of the existing coating conditions.
- e) Coating repair on the pipeline shall be extended minimum 5.0 m from the edge of road or to the extent where access restriction for future coating repair is expected due to the presence of road or railway infrastructure.

5.4.2.4 Pipeline Protection at Road Crossing

Existing DUSUP Pipelines has been verified for the minimum depth of soil cover in accordance with API RP 1102, ASME B31.4/B31.8 and minimum burial depth required from the ground level or bottom of road foundation to the crown of the pipeline is 1.2m, or 2.0 meter below finished road level, or as per the crossing requirements of RTA; whichever is greater.

Pipeline protection must be complete to the approval of DUSUP before commencement of subsequent construction works within the NOC witnessing zone.

The likelihood of vehicle rollover with a high severity outcome increases significantly where the embankment height exceeds 1.5 m and embankment slopes are critical (steeper than 1 on 3). Therefore road with embankment height of 1.5m and above are considered as "elevated road".

Pipeline protection shall be extended beyond the edge of the road shoulder, edge of bridge or toe of the embankment whichever is greater as follows:

- a) Roundabout, Curved road (including slip road), *Elevated road with embankment slope of 1:3 of steeper and bridge crossing - 20 meters.
- b) At grade straight road - 10 meters.

- c) Straight Road with embankment of 1:3 or flatter slope - 10 meters
- d) New road crossings and interchanges within the DUSUP corridor, protection slab shall extend to within DUSUP's existing / proposed fence limit or as per above conditions, whichever is greater.

*Road raised 1.5 meter and more above the grade level.

Note: Refer to "DUSUP Typical Road Crossing Arrangement" drawing reference: 900-08-03-01 (Attachment 1).

- e) Pipeline berms within future or proposed roundabout/junction or interchange ROW section shall be provided throughout the ROW section (DUSUP fence to fence), over and above the pipeline protection slab requirements detailed in 5.4.2.4 a) to d). Any existing berms may require berm rehabilitation when new crossings are provided to achieve standard pipeline berm requirements as shown on DUSUP drawing reference 900-08-055 (Attachment 2).
- f) An initial pre-concreting visual quality check on the precast protection slab must be carried out by the project consultant in the presence of DUSUP representative. A copy of consultants approved quality check documents for the slabs must be provided to DUSUP representative at site before commencement of the installation of slabs.
- g) If the pipeline depth is deep such that upon excavating at 2.5m under a road, no pipeline is found (refer to Trial Pit Guidelines DP-OPSON-0148), road protection slabs shall still be required. The contractor may add concrete slabs at just below road surface level to ensure appropriate slab protection.

5.4.2.5 Pipeline Protection at Railway Crossing

- a) The consultant must carry out the Design Hazard Analysis specific to the proposed railway crossing, identifying all possible design-related hazards to the existing pipelines and facilities, risk associated with the design related hazards and incorporate necessary mitigation measures in the design and demonstrate that the risk have been mitigated to As Low As Reasonably Possible (ALARP).
- b) The design of railway route at the crossing location must include a robustly constructed derail containment system in order that the horizontal deviation of a derailed train can be contained against derailment to the full width of DUSUP corridor/existing DUSUP facility.
- c) The consultant must verify site conditions that could affect the safety and practicability of construction or operation in the presence of existing or planned DUSUP facilities (particularly above ground pipelines or valve station in the proximity of construction).
- d) Pipeline protection for the "At Grade" railway crossing shall be designed as per the relevant AREMA code. However depth of pipeline from the base of rail shall be not less than 10'-0" (~3.0m) or at the level where vibration level from the railway operation to pipeline remain less than 40mm/sec or as per the Railway Agency vertical separation requirements; whichever is deeper, to the approval of Pipeline Technical Authority (TA) of DUSUP/DPE.
- e) Pipeline at Railway or Metro crossing shall be protected to the full width of railway protection zone, 30 meters from the edge of railway viaduct or shall be extended to within the DUSUP fence, whichever is greater.

- f) Pipeline protection installation (including pipeline berms) must be complete to the approval of DUSUP before commencement of subsequent construction works within the NOC witnessing zone.
- g) Minimum clearance between top of pipeline and bottom of the protection slab after final (long term) settlement of slab shall be 950 mm.
- h) Note that the effect on stray currents vastly differ if the train / metro is diesel driven or is electrical; electrical trains / metro may have a severe effect on stray current on the DUSUP pipelines, which shall be mitigated against during the design stage. NOC engineer shall refer to stray current monitoring in Section 5.4.2.9.

5.4.2.6 Pipeline Protection for Railway / Metro Crossing below

- a) For rail / metro crossings below the pipeline, similar conditions shall be set with regards to stray current monitoring / protection and vibration on the pipeline as for railways / metro crossing above the pipelines.
- b) Underground crossing signs shall be installed either side of the crossing at the edge of the pipeline corridor to assist in identification of the crossing.

5.4.2.7 Culvert Type Pipeline Protection

- a) Culvert design must consider the construction hazards particularly with respect to existing pipeline(s) and reducing risk from the construction hazards to ALARP level.
- b) If the patrolling access is to be incorporated within the pipeline protection culvert, the design must consider minimum one (1) meter 360° maintenance access to the pipeline without having to provide any support to the structure. Top of the culvert foundation shall be lowered minimum one (1) meter from the bottom of pipeline.
- c) Minimum 500mm selected sand cover must be provided above the crown of pipeline and air gap of minimum 8" (200mm) must be maintained between the bottom of culvert cover slab and soil fill. Ends of culvert must be sealed to suit the functional requirement of vent.
- d) The gap between the at grade cover slabs shall be sealed with approved sealant.
- e) Vent pipes must be provided on both ends of the culvert type protection. Ends of culvert shall be closed and gap around the vent shall be sealed to ensure efficient functioning of vent.
- f) Total weight of precast cover slab of culvert must not exceed 2.0 MT.

5.4.2.8 Crash Barrier Protection

- a) While designing of roadside crash barriers the road consultant shall ensure that the hazards are identified considering crash history, traffic volumes, speed, clear zone, road geometry, roadside topography, surface condition, and the expected severity outcome of crashes into the roadside hazard/pipeline.
- b) As a minimum requirement, crash barriers must be provided for 20 meters on the approach to and for 8 meters on the leaving side of a road crossing. The crash protection may be either concrete "Jersey Type" barriers or steel guardrail type as approved by Roads & Transport Authority (RTA) and DUSUP.
- c) Steel guardrail (Metal crash barriers) may be accepted if the bottom of terminal post/intermediate post or end posts are minimum one meter above topmost pipeline in the corridor and vertical posts are equally spaced with minimum separation of 1.6m as shown below:

- d) Special Crash barriers shall be provided at critical facilities such as Block Valve Stations, Piggings Stations and Dubal Corner Manifold plot, the existing facility shall be protected with specially designed concrete crash barrier as shown on DUSUP drawing reference: 900-08-024 (See Attachment 3).
- e) For the road bridge and viaducts crossing over the DUSUP corridor, purpose designed crash barrier to test level 6(TL6) with the minimum height of 1.5 meter shall be provided in accordance with the Bridge Design Standard AS 5100.
- f) The railway bridge/viaduct or ramp at the crossing location must be provided with a purpose designed crash barrier with minimum height of 2050mm (TL-6 barrier). The design and extent of the crash barrier must be as per the international standard or as per the best industry practice.
- g) DUSUP provided barriers are typical, however Contractor shall establish that the proposed barriers are capable of withstanding the loads estimated by the Contractor.

5.4.2.9 Cathodic Protection (CP) Test Posts

- a) Existing Cathodic Protection system affected by the proposed works must be relocated to an approved location. The contractor scope must cover the relocation of the CP system by a DUSUP approved specialist subcontractor and the proposal must be approved in advance by DUSUP. While relocating the CP system, the existing CP posts may need replacement. All cost related to the relocation shall be borne by the Road Contractor.

Splicing of cables is not permitted. Hence following remedial shall be considered:

Uncased road crossing: In case of uncased road / railway crossing, existing test post shall be discarded and a new test post on like to like basis shall be installed. DUSUP/DPE approval shall be obtained if is planning to install different type of test post.

Cased road crossing: In case of cased road / railway crossing, if casing is not extended to cover the extent of the road, test post shall be relocated to suitable place with a new set of cables connected to the casing and carrier pipe. Existing cables connected to the casing and carrier pipe shall be removed.

- b) For road crossings <10m in width, as a minimum a new Cathodic Protection (CP) test posts for the pipeline(s) must be installed at the road crossing on the downstream side of the pipeline. For road crossings ≥ 10 m in width, two monitoring test posts, and one at each side shall be provided. Test posts are preferably located within the fenced corridor. CP Test post in open area shall be protected with approved metal or concrete crash barriers. All cost related to the new CP Post shall be borne by the Road Contractor.
- c) Design and installation of test posts must be carried out by the DUSUP approved specialist contractor, and shall be first introduced for review in the Design NOC Stage.
- d) For the railway crossing the Consultant must ensure and demonstrate that no stray current on DUSUP pipelines exists by verification (field measurements before operation, during commissioning and after commercial start up). Stray current monitoring shall be carried out before railway operation, during commissioning and after commercial start as per the DUSUP approved procedure. Additionally, monitoring must be carried out annually after start of full operation. Any interference must be mitigated by the client at their cost.
- e) The railway consultant must provide all necessary design information and drawings for DUSUP to carry out review of stray current calculations and stray current protection systems from a specialist consultant.

- f) The railway Consultant must consider installation of coupons, reference electrodes and test boxes as per DUSUP requirements/specifications in the vicinity of the railway crossings for monitoring stray currents at no cost to DUSUP.
- g) In addition to the NOC, DUSUP Permit of Work will be required for all Cathodic Protection Test Post work.

5.4.2.10 Relocation of Vent

- a) Existing vent affected by the new road/railway shall be extended and relocated to the approved location within the fenced corridor or if located outside the corridor, vent shall be protected with approved barrier and signage. All cost related to the relocation shall be borne by the Road Contractor.
- b) Extension shall be made using coupling connection, coupling shall be wrapped with corrosion wrap and mechanical protection (PVC) wrap. Flange connection is not permitted. If the existing vent is damaged and not possible for coupling, alternative solution proposed by the DUSUP shall be installed.
- c) Where possible, horizontal extension shall have upward slope for easy venting.
- d) The vent pipe specification is as follows:
 - 2" NB API 5L Gr. B Sch. 80. The pipe should be wrapped with Denso tape (or equivalent) up to 1'0" above ground and vertical section extend not less than 4'-0" aboveground.
 - Top of vent pipe shall be fitted with down-turned elbow properly screened, or a relief valve. Vents in locations subject to high water shall be extended above the maximum elevation of high water and shall be supported and protected in a manner that meets the approval of the DUSUP. Vent pipes shall be no closer than 4 ft. (vertically) from aerial electric wires.
- e) Where applicable horizontal extension of vent pipe shall cross below pipeline protection slabs to enable future removal of slab protection for the maintenance.
- f) Holiday test shall be completed in the presence of the DUSUP Representative to be completed to confirm the integrity of the coating after installation.
- g) In addition to the NOC, DUSUP Permit of Work will be required for all vent relocation and extension work.

5.4.2.11 Pipeline Warning Signs

- a) Road Crossing (RX) - Pipeline Warning Signs (Refer to Attachment 4 Drawing 900-08-004-001 for foundation and post details) shall be installed either side of highway crossing; they shall be set back slightly from the edge of the road shoulder or behind crash barriers and at the approaching edge of the corridor.
- b) Railway Crossing (RX) - Pipeline Warning sign (Refer to Attachment 4 Drawing 900-08-004-001 for foundation and post details) shall be installed on either side of railway crossing; they shall be set back slightly from the railway restriction zone at the agreed location. The crossing identification (RX number) shall be included on the signage panel.



Figure 1 - Road / Rail Crossing(RX) Sign

- c) Existing pipeline warning signs affected by the road works must be relocated to the approved location at the agreed location. Changed KP marking (Chainage) must be updated by replacing existing KP reading sticker in white strip at the bottom of signage. Signage damaged during the work shall be replaced with new signage as per DUSUP drawing reference : 900-08-004-001(See Attachment 4).

5.4.2.12 Access Through Elevated Road

Construction of an elevated road on the soil embankment across the DUSUP corridor may result in discontinuity of patrolling / corridor access. If the height permits, the road design must include unrestricted access arrangement such as all-weather underpass within the embankment (see sample picture below). Underpass shall be minimum 4.0M wide and 2.5 meter high (vertical clearance).



Figure 2 Underpass Example

If the underpass cannot be accommodated due to the inadequate embankment height or road geometry or other impediments, alternate safe and efficient two way patrolling access arrangement shall be included in the design.

5.4.2.13 Corridor Access and Security

- a) DUSUP corridor shall remain secured with fence and access at all times, before during and after construction of road. Existing corridor fence opened for the construction road shall be modified as per the approved ROW interface with two gates on each sides of crossing and fence shall be located at appropriate distance from the toe of the embankment (not within the slope of embankment) and to enable safe vehicle maneuvering from the access gate to the patrolling track as shown on the sketch below:

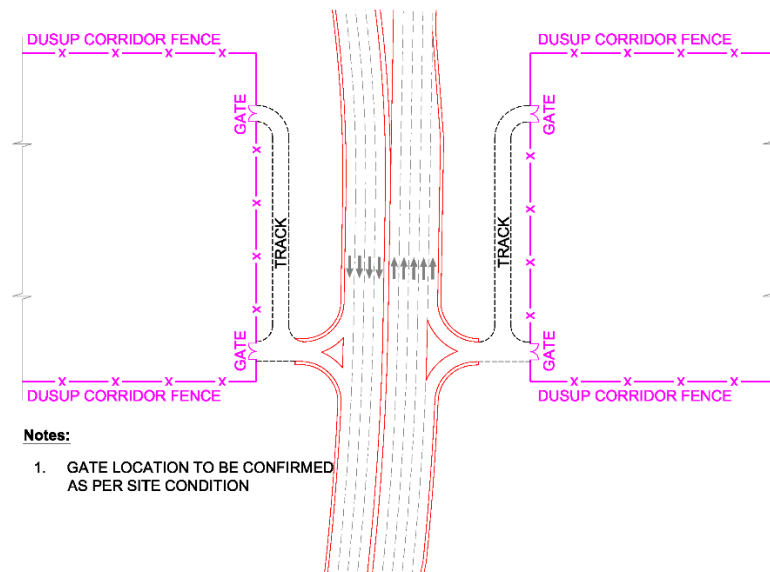

Figure 3 Corridor Access

- b) If patrolling access to pipeline within the interchange area is not practicable, a roadside layby must be constructed for DUSUP as part of the proposed road in order that DUSUP staff can safely park the vehicle and carryout the pipeline inspection by walking to pipeline location. An approved DUSUP parking sign must be installed at the layby location. Drop curbs / cut curbs shall also be incorporated into the design to ensure ease of access for the DUSUP vehicles.
- c) Corridor fence and gate shall be provided as per the DUSUP standard drawing reference: 900-08-017, Sheet 001 & 2 (See Attachment 5 & 6).
- d) A pipeline warning sign must be installed on each gate as shown on drawing reference: 900-08-047-001(See Attachment 7)
- e) Access between the road and corridor access gates shall be protected with minimum 300mm thick compacted road base erosion protection and any utilities affected by the DUSUP patrolling access shall be protected as per relevant authority's requirement. Width of access shall be minimum 4.0m.
- f) If applicable, patrolling access ramp shall be constructed with 1:6 or flatter slope.
- g) Should DUSUP fence crossing above DUSUP pipelines require to be relocated (i.e. from an extension of RTA ROW at road crossing), trial pits above the pipelines are not required on the basis that the fence is perpendicular (90 degrees) to the pipeline and the fence foundations are equally placed away from the pipelines (refer to Attachment 5 for fence details). If the new fence is at a 60 degree angle or less from the pipelines, trial pits

at the pipeline crossing location will be required for placement of the fence foundations. For any brick walls / compound walls crossing the pipelines, trial pits are a requirement to identify the depth of the pipeline, and the brick walls / compound walls will cross as close to perpendicular (90 degrees) to the pipeline as possible.

- h) For new location of fence (i.e. from an extension of RTA ROW at road crossing) contractor shall provide demarcation certificate for review during the construction NOC stage to ensure that the fence location is correctly placed – DUSUP pipeline representative shall meet Contractor at site to confirm. Further, once the construction is complete, contractor shall provide the updated fence demarcation certificate (as part of NOC close out) to ensure that the fence is correctly placed and consistent with the demarcation certificate provided during the construction phase. The demarcation certificate and the new fence shall be confirmed by the DUSUP Pipeline Representative at site. DUSUP will then appropriately update the DUSUP Corridor fence limits in the DUSUP GIS.
- i) Changes in Access Gate locations shall be agreed in the Design Phase with the Pipeline ROW Team. If a new development blocks an existing gate, contractor shall provide new gate access and if required, appropriate access protection above the pipelines to allow vehicle movement to reach the existing vehicle path.
- j) Patrolling access within newly landscaped area (within ROW) must be unrestricted and approved by RTA ROW department.

5.4.2.14 Temporary Road above Pipelines

For temporary roads above the DUSUP pipelines, if no existing protection slab is in place as confirmed by trial pits, minimum soil cover of 1.2m shall be assured within the DUSUPs fence corridor, a 20 mm steel plate may be placed over the crossing location and be extended 1m beyond the pipeline edge. If temporary access is required for more than 1 month, DUSUP approved typical protection slab (attachment 1) shall be placed at the crossing location.

For temporary roads above the pipeline not within DUSUP's fenced corridor, DUSUP approved standard protection slabs shall be provided.

All temporary roads above the pipelines require crash barriers and temporary road signs accordingly. For all crossing locations, appropriate road base shall be provided to reduce potential sand erosion of the area, and once the temporary access is no longer required, area shall be reinstated to pipeline representative satisfaction. Should DUSUP request that the protection slabs remain, Contractor shall submit as built of protection slab location as part of the NOC Close Out.

5.4.2.15 Protection from Rainwater Washout

- a) Rain water discharge from the proposed road or railway infrastructure shall not be directed to the DUSUP corridor to ensure that the corridor is protected from washout or erosion of pipeline berm or damage to corridor fence.
- b) Storm water drain soak way shall be located at the safe distance from the pipeline to ensure that pipeline corridor/pipeline berm is protected from erosion from any overflowing of soak away.
- c) Where interchange with loops crosses corridor, the storm water drainage system shall be designed to keep the pipeline corridor area dry.

5.4.2.16 Planting, Vegetation and Beautification

Pipeline are treated with a protective coating to resist corrosion and carry a small amount of direct current. Tree roots are drawn to loose soil around the pipeline and the consistent temperature generated by the moving gas. They can damage the coating, coming into contact with the steel pipeline. Since roots are carrying water and nutrients to the tree, they act as conductors of electricity, absorbing the electrical current that is meant to stop corrosion.

While damage and increased fire risk are issues from trees for above ground assets, damage to pipeline coating are issues for below ground assets.

Therefore planting of tree is not permitted within the pipeline corridor.

- a) In general, planting of small plants/shrubs or grass within road ROW/Corridor interface area, but outside the “No Go Zone” of pipeline may be permitted after DUSUP review, provided the roots of the plant are not capable of causing damage to the pipeline and approved root arrestor or other mitigation measure that would mitigate any damage to the gas pipelines is provided. However, free passage shall be maintained along the pipeline route.
- b) Inside the 5-metre “No Go Zone” loosely laid gravel layer may be accommodated instead of grass after further consultation with DUSUP.
- c) Trees parallel and outside the corridor fence may be planted provided that the separation distances and the expected height of the fully grown plant are taken into account so that the security of corridor is not compromised, plant cannot fall onto any corridor fence or above ground asset, nor the roots interfere with the pipeline fence, pipeline or below ground assets. Tree should have approved root arrestors if located within 5 m of fence line, and trees are not be permitted within 10 meters of pipeline in unfenced areas.
- d) Any approval granted to plant within DUSUP pipeline corridor or corridor interface area within ROW is subject to DUSUP retaining the rights to remove at any time in the future all vegetation which DUSUP consider may restrict access or endanger the pipeline with no cost to DUSUP. If plant to be reinstated the cost of reinstatement or other improvement works shall be borne by the owner of such plant. Contractor / Client is required to raise an undertaking letter stating such as part of the NOC submission.
- e) Large sign boards within ROW for developments may be permitted within DUSUP corridor but not inside the 5-metre pipeline “No Go Zone, and the sign boards shall be easily removable if required for pipeline maintenance or for future pipeline construction. Placement of large sign boards shall take into account prevailing wind to ensure that the sign boards do not fall on top of the pipelines during storm / high winds.

6 DUSUP NOC CLOSEOUT

For DUSUP NOC Close-Out Requirements refer to:

DUSUP NOC Standard Conditions - DP-OPSON-0056

7 DUSUP GUIDELINES

Various Guidelines for DUSUP/DPE Onshore pipelines have been developed for use. Reference can be made to the following link: <https://dusup.ae/dusup-noc-guidelines/>

Attachment 1: Pipeline Protection Slab

AutoCAD File Location: \\900 - General\08 Civil, Structural, Buildings\900-08-003-001 - Typical Road Crossing - Rev 0.dwg
 VarghB January 27, 2025 11:50am

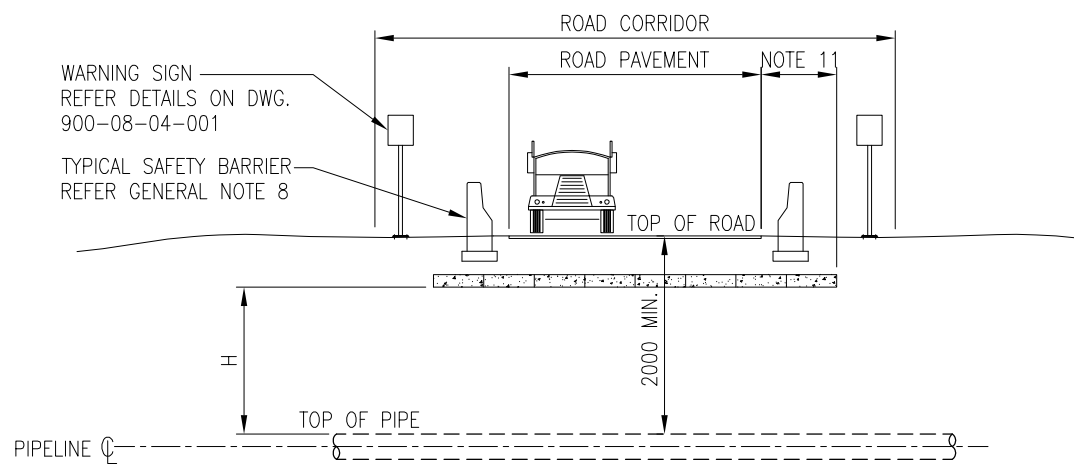

TYPICAL ROAD CROSSING OVER EXISTING PIPELINE

SCALE=NTS

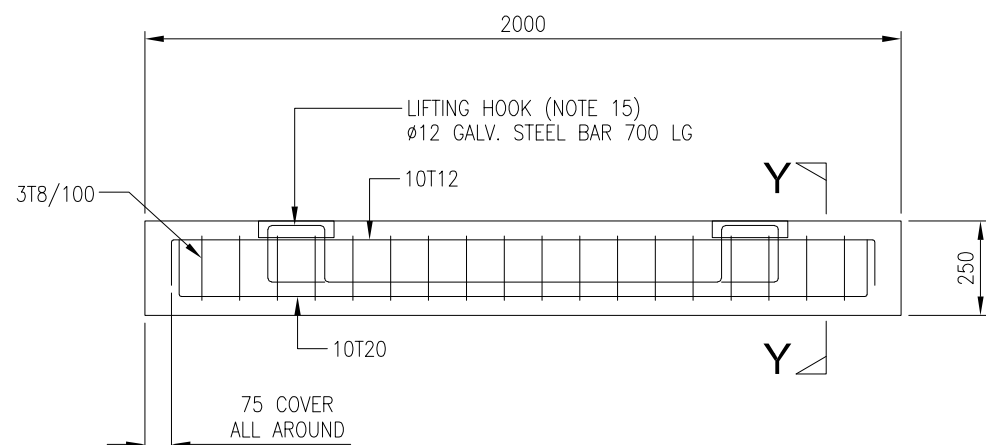

SECTION 'X'-X'

SCALE=1:20

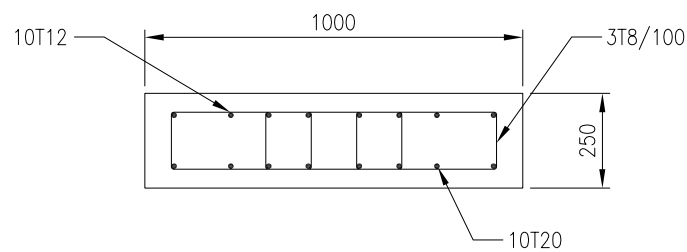

SECTION 'Y'-Y'

SCALE=1:20

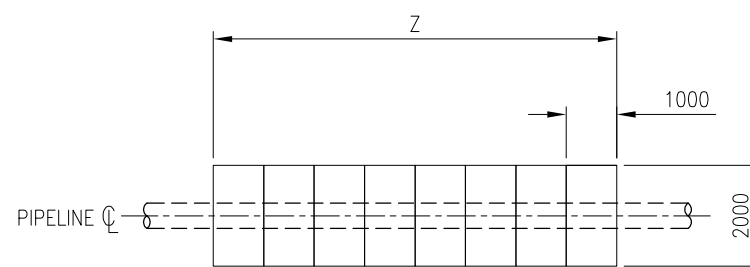

PLAN VIEW

SCALE=NTS

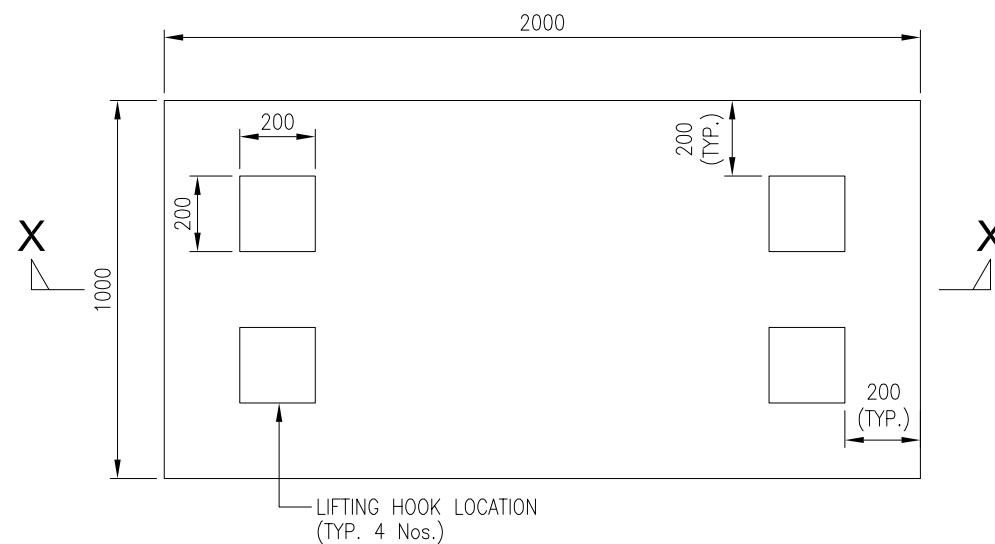

PRECAST RC SLAB

SCALE=1:20

GENERAL NOTES:

- All dimensions are in millimeters unless noted otherwise.
- Pipeline road crossing designed in accordance with latest revision of API RP 1102, ASME B31.4/ B31.8.
- Pavement width is considered vehicular loading width whether paved, crushed stone or sand.
- Whenever possible roadways shall cross the pipeline at right angles.
- Where a roadway is to cross a pipeline, the pipeline must be surveyed for coating defects to assess the need for any repairs. If repairs are required, the pipeline must be excavated & sand blasted clean after inspection. Any repairs to the pipeline are to be primed and recoated according to **DUSUP** specification. This work is to be done by or under supervision of **DUSUP** personnel at the expense of those persons carrying out the work.
- Compaction of backfills shall be as follows:
 - < 400mm all around :By hand tamping equipment in lifts not greater than 100mm.
 - 400mm - 1000mm :By manually operated vibratory Plate in lifts not greater than 100mm.
 - > 1000mm :By conventional earth moving equipment, other than vibratory rollers.
- Vibratory rollers to a maximum dead weight of 15 te cannot be used within a distance of 3m offset. Vibratory rollers of a greater weight are subject to approval.
- Safety barrier length to be minimum 20m approaching, 20m leaving for Two-way road without a dividing barrier and 20m approaching, 8m leaving for Two-way road with a dividing barrier. Offset distance from pavement shall be defined with local authority at site. Necessary approval shall be obtained from Govt. or other relevant authorities for safety barrier design and construction, where required.

SLAB PROTECTION NOTES:

- Slab protection required as per approved NOC.
- Slab detail typical only. Bars are high yield steel grade 460 (Type 2).
- Dimensional specification
 - H: To be maximised, minimum 950.
 - Z: Refer to DUSUP Guidelines for Road and Rail Infrastructure Crossing (DP-OPSON-0152) for Protection Slab length under Road Crossing..
- Maximum gap between slabs shall be 20mm.
- Slabs shall be maximum weight of 2.0 tonne.
- Concrete particulars as follows:
 - Grade 30/20
 - Minimum cement content 660 lbs/cyd
 - Maximum water cement ratio 0.40
 - No admixtures shall be used.
 - Cement for all concrete construction shall be Type=V Sulphate resisting cement.
 - Concrete shall be mechanically vibrated.
 - Slab shall be tanked with bituthene 1200HC or equivalent membrane installed as per manufacturers' recommendations.
 - Slab shall be cured in accordance with normal UAE practice.
- If slab is located at ground surface level, then dependent upon crossing location, Marl / Road base material of 2m width to be added to slab perimeter to prevent local scouring, may be specified.
- Lifting hooks of protection slabs must be wrapped with DENSO tape and covered with cement sand mortar before backfilling.

bv

Rev.	Date	Revision Description	Drawn	Checked	Approved
0	27.01.25	GENERAL REVISION	BV	SK	RRN/ NB
D	25.06.06	36" & 48" Pipeline Data Added	BV	RES	ACS
C	04.09.05	Approved For Construction	BV	RES	ACS
B	30.08.05	Approved For Construction	BV	RES	ACS
A	05.07.05	Approved For Construction	KRM	SAR	GW



TYPICAL ROAD CROSSING PROTECTION DETAILS

CAD File Name	Size	Scale	Area Code	Doc Code	Serial No.	Sheet of	Sheets	Rev. No.
900-08-003-001-RD	A3	As Stated	9 0 0	0 8	0 0 3	0 0 1	0 0 1	0

Attachment 2: Pipeline Protection at Road Curves

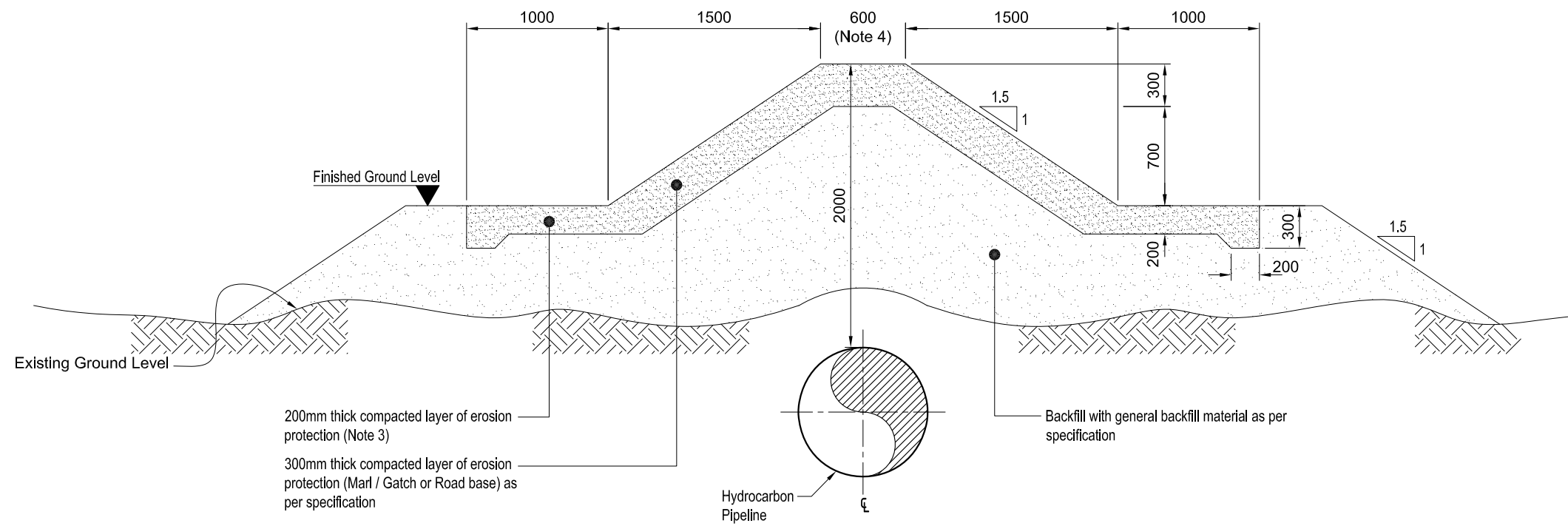

TYPICAL CROSS SECTION OF BERM

NOTES:

- All dimensions are in millimeters unless noted otherwise.
- If the clearance between existing grade to the top of pipeline is less than 1000mm, area under the new berm must be backfilled and manually compacted to achieve minimum 1000mm cover. The backfill material shall be as per specification (Selected Fill Material)
- To prevent any possible scouring one meter wide erosion protection shall be added.
- Minimum 600mm or pipe diameter, whichever is greater

Rev.	Date	Revision Description	Drawn	Checked	Approved
0	29.04.20	Issued for Information	BV	RKS	NB



Dubai Supply Authority

PIPELINE PROTECTION AT ROAD CURVES
TYPICAL CROSS SECTIONS

CAD File Name	Size	Scale	Area Code	Doc Code	Serial No.	Sheet of	Sheets	Rev. No.
900-08-055-001-R0.DWG	A3	1:40	9 0 0	0 8	0 5 5	0 0 1	0 0 1	0

Attachment 3: Crash Barriers at Block Valve Stations

NOTES

1. ALL DIMENSIONS ARE IN MILLIMETRES UNLESS NOTED OTHERWISE.
2. CO-ORDINATES ARE BASED ON TRANSVERSE MERCATOR PROJECTION, WGS84 SPHEROID, DLTM DATUM.
3. ALL BOLTS SHALL BE GALVANISED AND GRADE 8.8, CONFORMING TO BS 4190, BASEPLATE SHALL BE HOT DIP GALVANISED.
4. THE THICKNESS OF BLINDING SHALL BE 75mm. THE CRUSHING STRENGTH SHALL BE 15 N/mm² AT 28 DAYS AND SHALL CONTAIN SULPHATE RESISTING CEMENT.
5. THE CONCRETE GRADE FOR R.C. WORKS SHALL BE C40 AND SHALL CONTAIN ORDINARY PORTLAND CEMENT WITH A MIN. CEMENT CONTENT OF 350 kg/m² WITH A MAXIMUM WATER CEMENT RATIO OF 0.40.
6. ALL EXPOSED CONCRETE TO HAVE HYDROCARBON RESISTANT EPOXY COATING.
7. UNDER GROUND CONCRETE SHALL BE PROTECTED WITH BITUTHENE 1000 HC AND 25 THICK SAND CEMENT SCREED.
8. ALL REINFORCEMENT TO BE HIGH YIELD STEEL WITH CHARACTERISTIC STRENGTH OF 420 N/mm² TO BS 4449 OR EQUIVALENT. AND SHALL HAVE A COVER OF 70mm BELOW GROUND AND 50mm ABOVE GROUND EXPOSED TO WEATHER.
9. ALL EXPOSED CONCRETE EDGES OF CONCRETE SHALL HAVE 25x25 CHAMFER.

LEGEND

1. GR. LVL. GRADE LEVEL
2. MDD MAXIMUM DRY DENSITY

REFERENCE DRAWINGS

REV	DESCRIPTION	BY	CHKD	APPD
0	ISSUED FOR APPROVAL			



هيئة دبي للتجهيزات
Dubai Supply Authority
P.O. Box 207 Dubai, United Arab Emirates
Tel +971 4 3531990
Fax +971 4 3532619

DRWN	SMN	TITLE:	
CHECKED	SL	MAINLINE BLOCK VALVE STATION	
APPROVED		CONCRETE CRASH PROTECTION BARRIER	
SIZE			
SCALE			
PROJECT NO.	DRAWING No.	SHT.No.	REV.
	900-08-024	01	0

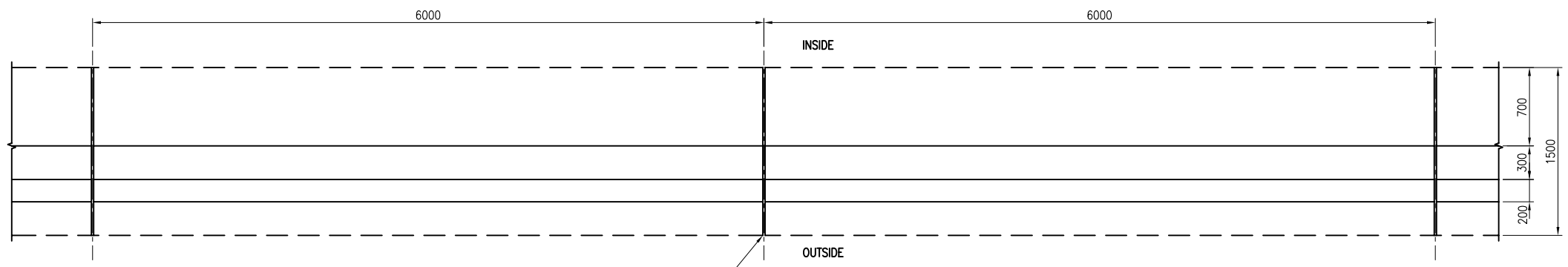

PLAN OF CRASH PROTECTION BARRIER
(SCALE 1:20)

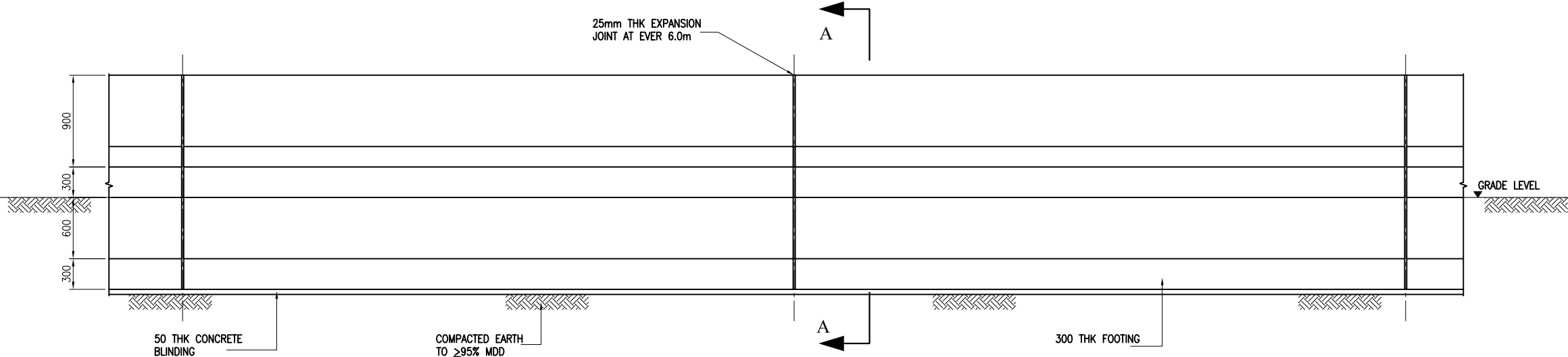

ELEVATION OF CRASH PROTECTION BARRIER
(SCALE 1:25)

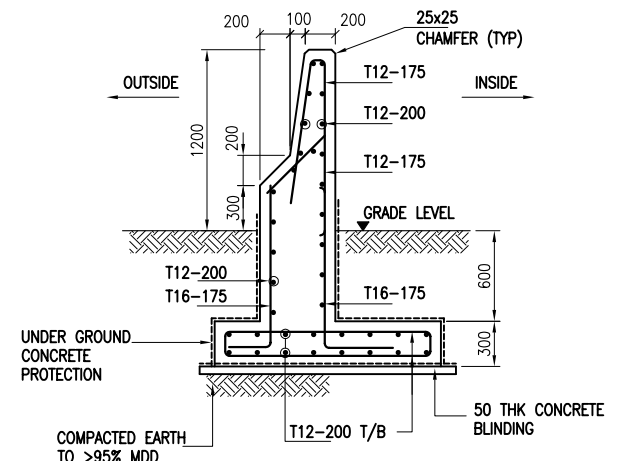

SECTION A-A
(SCALE 1:25)

Attachment 4: Pipeline Warning Signs

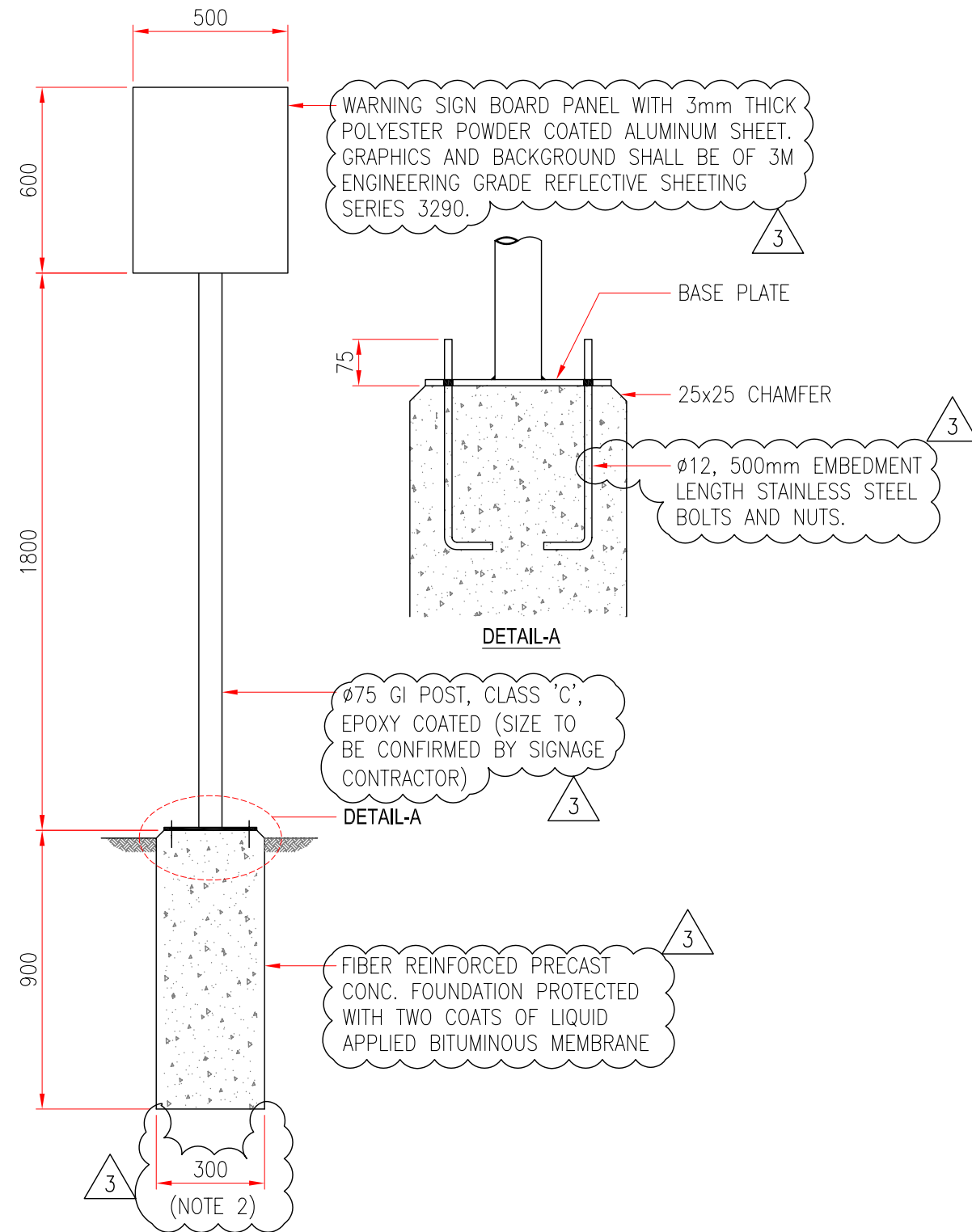

FOUNDATION AND POST DETAILS

SCALE=1:10

GENERAL NOTES:

1. ALL DIMENSIONS ARE IN MILLIMETERS UNLESS NOTED OTHERWISE.
2. THE CONTRACTOR SHALL DESIGN THE SIGNAGE FOUNDATION, ANCHOR BOLTS, SIGN POST AND FIXINGS FOR MAXIMUM WIND SPEED 150 Km/Hr. DESIGN CALCULATION AND DRAWINGS SHALL BE SUBMITTED FOR MDE REVIEW.
3. SIGNAGE SHALL BE SINGLE SIDED WITH 3mm THICK POWDER COATED ALUMINIUM SHEET. GRAPHICS AND BACKGROUND SHALL BE OF 3M ENGINEERING GRADE REFLECTIVE VINYL FILM.
4. SIGNAGE SHALL BE MOUNTED ON SINGLE POST HOT DIP GALVANISED TO 85 MICRONS AND PAINTED AS FOLLOWS:
 - i) DE-GREASE, APPLY MORDANT WASH ETCH PRIMER.
 - ii) PRIME COAT WITH TWO-PACK EPOXY POLYIMIDE TO DFT 125 MICRONS.
 - iii) TWO-PACK POLYURETHANE TOP COAT TO 50 MICRONS.



WARNING SIGN FORMAT

SCALE=NTS

3	09.10.06	REVISED AS CLOUDED	BV	RKS	ACS
2	05.04.06	COLOUR CODE ADDED	BV	RKS	ACS
1	15.02.06	REVISED ADDING WARNING SIGN DATA	BV	RKS	ACS
0	09.07.05	ISSUED FOR TENDER	BV	RKS	ACS
REV	DATE	REVISION DESCRIPTION	DRAWN	CHECKED	APPROVED

CAD FILE NAME	SIZE	SCALE	AREA CODE	DOC CODE	SERIAL NO.	SHEET OF	SHEETS	REV. NO.
900-08-004-001-R3	A3	NTS	9 0 0	0 8	0 0 4	0 0 1	0 0 1	3

Attachment 5: Corridor Fence

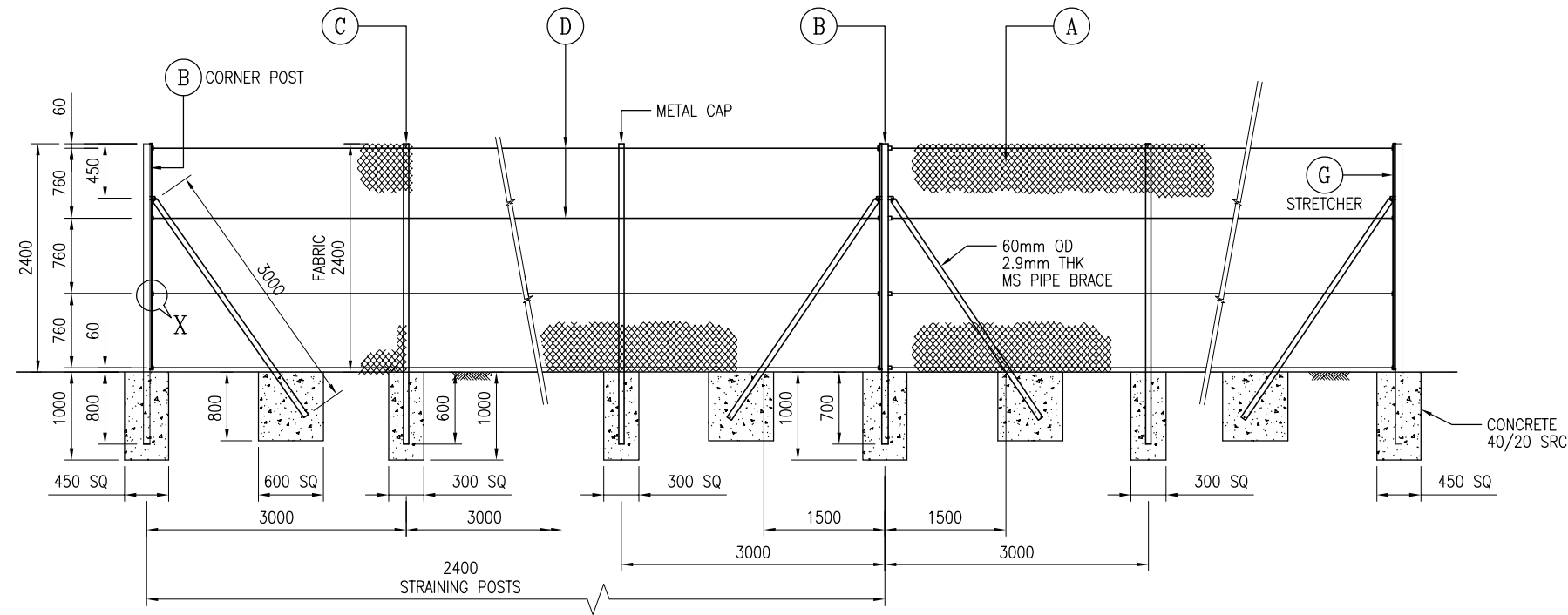

ELEVATION OF FENCING SYSTEM

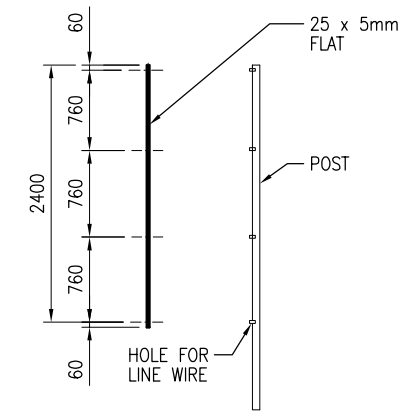

DETAILS OF STRETCHER BAR

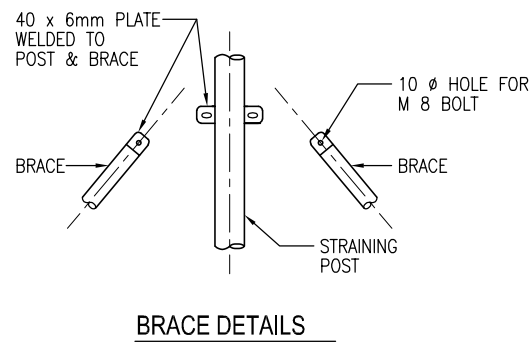
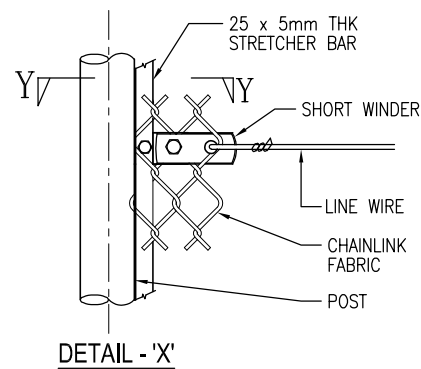
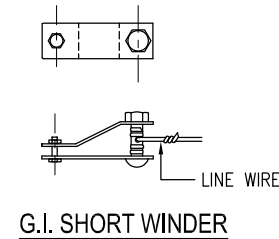
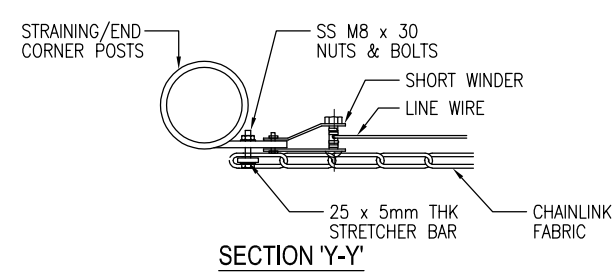
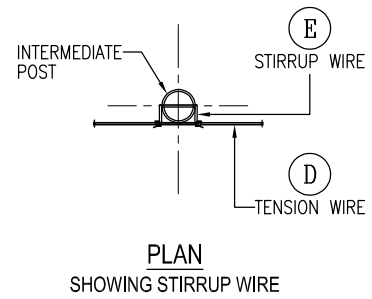

Sr. No.	Item	Specification
A	PVC Coated (BS) Chain link Fencing	3.55/4.75mm Dia PVC coated (BS) Fence height: 2.4m, Mesh size: 50 X 50mm, (Green colour)
B	Straining Post & Corner/End Posts	76.0mm OD MS Pipe (4.5mm.Thk.) with 2 nos. of 60.0mm OD MS Pipe (2.9mm. Thk.) Brace @ 24m c/c.
C	Intermediate Post	60.0mm OD MS Pipe (2.9mm. Thk.) at 3.0m centers.
D	PVC Coated (BS) Tension Line Wire	4 Rows - 3.55/4.75mm Dia PVC coated (BS) line wire
E	Stirrup Wire	2.7/3.8mm Dia PVC coated (BS) Stirrup wire
F	Tie Wire	1.8/2.6mm Dia PVC Coated (BS) Tie wire
G	Stretcher Bar	25 x 5mm THK MS flat - Stretcher bar

NOTES:

- All dimensions are in millimeters unless noted otherwise.
- All Wires & Fence shall be PVC Coated (BS).
- All metals shall be Hot Dip Galvanised to BS EN ISO 1461 & Polyester Powder Coated in Green colour (RAL-6005)
- All foundations shall be Bitumen coated. Post shall be Bitumen coated minimum 300mm above foundation.

Rev.	Date	Revision Description	Drawn	Checked	Approved
2	24.08.23	Revised as clouded	BV	SK	NB
1	04.08.13	Issued for Construction	BV	RSK	NB
0	12.03.07	Issued for Review/ Tender	BV	RSK	NB



Dubai Supply Authority

STANDARD DRAWING
PIPELINE CORRIDOR CHAIN LINK MESH FENCE
DETAILS (SHEET 1 OF 2)

CAD File Name	Size	Scale	Area Code	Doc Code	Serial No.	Sheet of	Sheets	Rev. No.
900-08-017-001-R2 - CHAINLINK MESH FENCE DETAILS SHT 1.dwg	A3	NTS	9 0 0	0 8	0 1 7	0 0 1	0 0 2	2

Attachment 6: Corridor Gate

AutoCAD® File Location : R:\900 - General\08 Civil, Structural, Buildings\900-08-017-002-R2 - CHAINLINK MESH FENCE DETAILS SHT 2.dwg
 : VarghB January 27, 2025 - 2:36pm
 Printed By

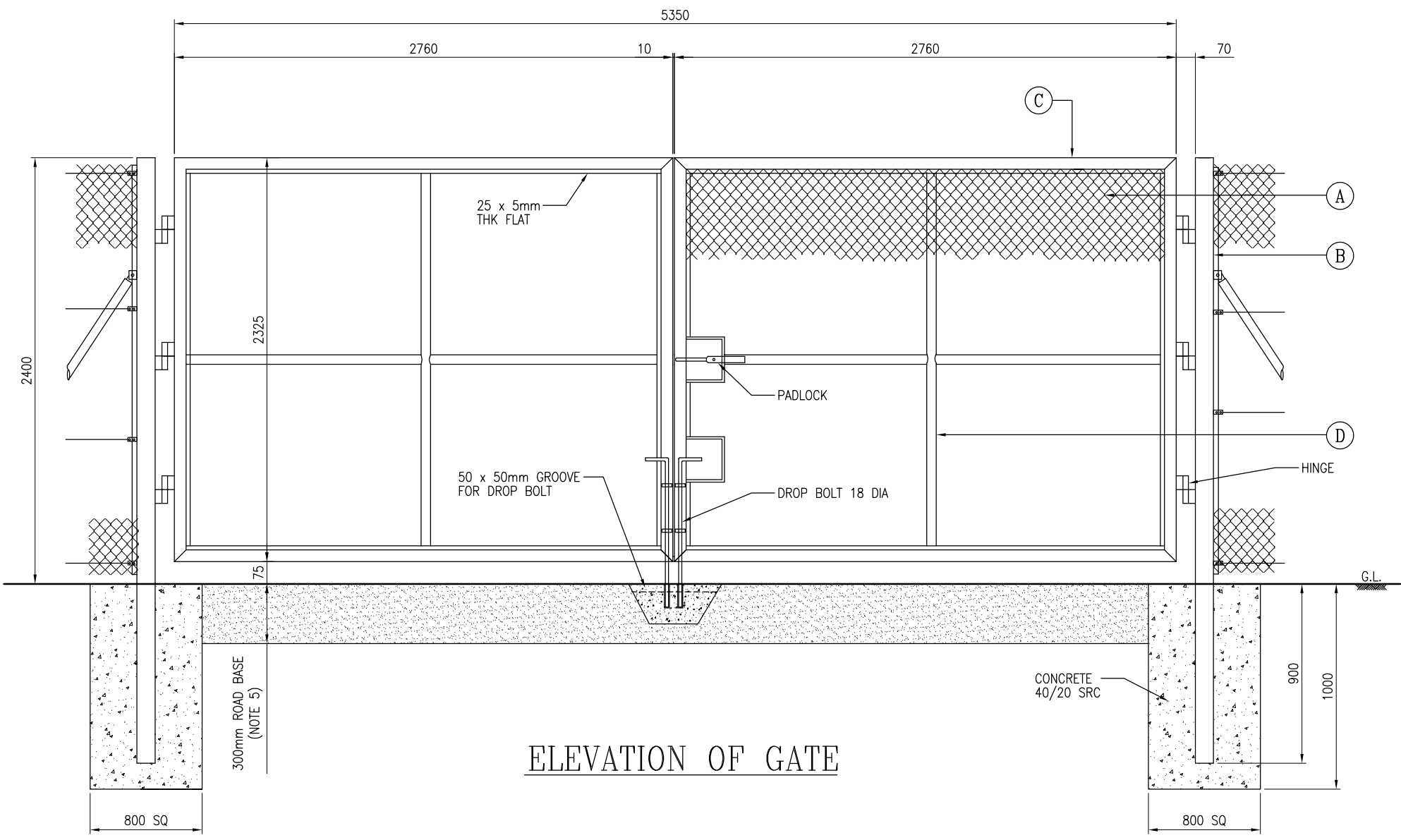

ELEVATION OF GATE

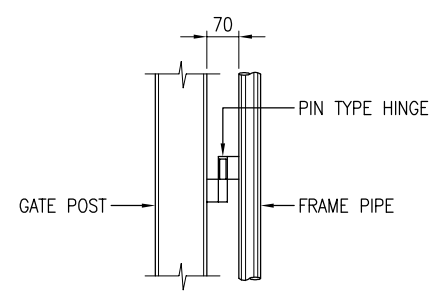

DETAIL OF HINGE

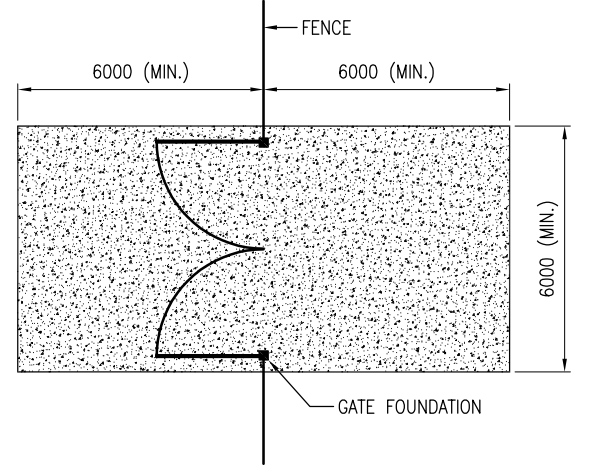

GATE HARD SURFACE LIMIT
(NOTE 5)

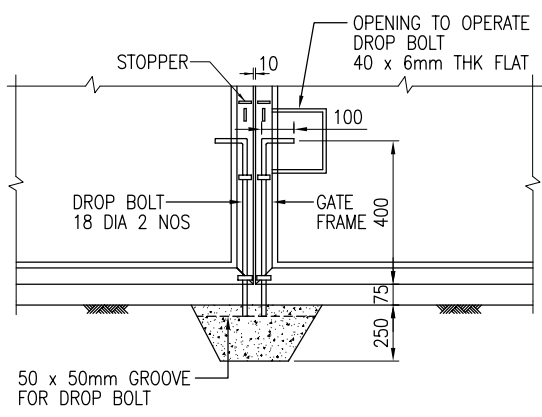

DETAIL OF DROP BOLT

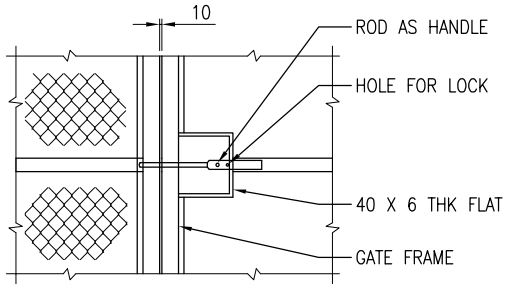

DETAIL OF PADLOCK

- NOTES:**
- All dimensions are in millimeters unless noted otherwise.
 - All Wires & Fence shall be PVC Coated (BS).
 - All metals shall be Hot Dip Galvanised to BS EN ISO 1461 & Polyester Powder Coated in Green colour (RAL-6005)
 - All foundations shall be Bitumen coated. Post shall be Bitumen coated minimum 300mm above foundation.
 - Access gate shall be surfaced with 300mm thick compacted road base or similar approved erosion protection material, and shall extend minimum 6 m from the end of the gate (either side). Sloped access to the gate shall be at a gradient of 1:6 or less.

SR. NO.	ITEM	SPECIFICATION
1.	A	3.55/4.75 mm DIA PVC COATED (BS.) (GREEN) CHAIN LINK FENCE MESH 50 x 50mm
2.	B	166.0mm OD (CLASS B) MS PIPE. GATE POST
3.	C	60.0mm OD MS PIPE (2.6mm THK) FRAME
4.	D	48.0mm OD MS PIPE (2.6mm THK) BRACING

Rev.	Date	Revision Description	Drawn	Checked	Approved
2	24.08.23	Revised as clouded	BV	SK	NB
1	04.08.13	Issued for Construction	BV	RSK	NB
0	12.03.07	Issued for Review/ Tender	BV	RSK	NB



STANDARD DRAWING
 PIPELINE CORRIDOR CHAIN LINK MESH FENCE
 DETAILS (SHEET 2 OF 2)

CAD File Name	Size	Scale	Area Code	Doc Code	Serial No.	Sheet of	Sheets	Rev. No.
900-08-017-002-R2 - CHAINLINK MESH FENCE DETAILS SHT 2.dwg	A3	NTS	9 0 0	0 8	0 1 7	0 0 2	0 0 2	2

Attachment 7: Fence Sign

GENERAL NOTES:

1. ALL DIMENSIONS ARE IN MILLIMETERS UNLESS NOTED OTHERWISE.
2. WARNING SIGN BOARD PANEL WITH 3mm THICK POLYESTER POWDER COATED ALUMINUM SHEET AA 1100. GRAPHICS AND BACKGROUND SHALL BE OF 3M ENGINEERING GRADE REFLECTIVE SHEETING SERIES 3290.
3. COLOUR CODE FOR BACKGROUND IS 3M ORANGE CW84
4. REFER DUSUP SOP-D-045 (IDENTITY MANUAL) FOR DUSUP LOGO AND SPECIFICATION



SIGNBOARD (FRONTSIDE)

SCALE=1:10

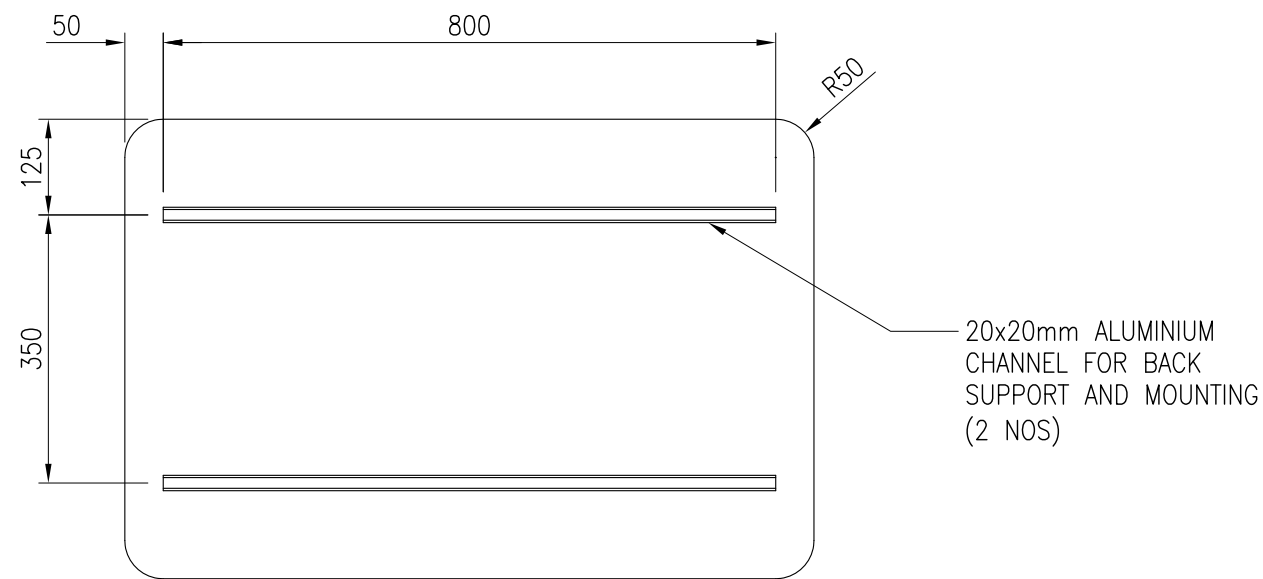

SIGNBOARD (BACKSIDE)

SCALE=1:10

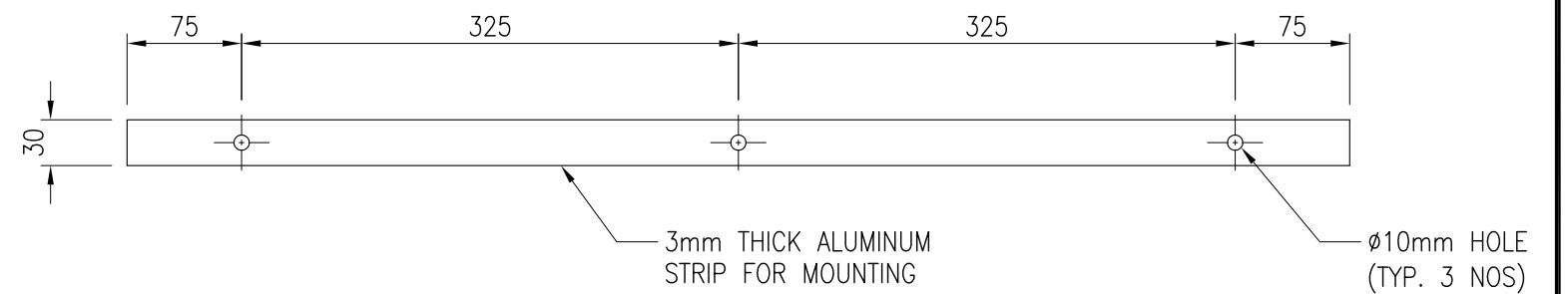

MOUNTING STRIP DETAILS

SCALE=1:5

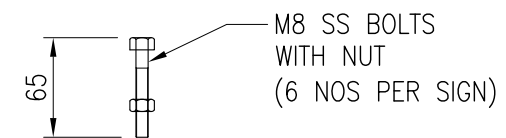

SS BOLT DETAILS

SCALE=1:5

						 Dubai Supply Authority			CORRIDOR AND FACILITIES WARNING SIGN STANDARED DETAILS					
0	28.12.15	FIRST ISSUE	HI	BV	RD	CAD FILE NAME	SIZE	SCALE	AREA CODE	DOC CODE	SERIAL NO.	SHEET OF	SHEETS	REV. NO.
REV	DATE	REVISION DESCRIPTION	DRAWN	CHECKED	APPROVED	900-08-047-001-R0.dwg	A3	NTS	9 0 0	0 8	0 4 7	0 0 1	0 0 1	0